

Can I use Clipon Risers on my bike?

There are a number of factors that determine if your motorcycle can utilize clipon risers. By taking the steps below you will better be able to determine if risers will fit on your motorcycle without substantial modifications. Other factors to be considered are brake line length and cable routing, which should be carefully considered during the installation process. If you have any questions, please do not hesitate to call Woodcraft. Proper installation is critical to rider safety and should be performed by a certified technician.

Measure Clearance

The first step in evaluating your motorcycle for risers is to rotate your bars from lock to lock and measure the clearance both above and forward of the controls (see **Figure 1**). These measurements need to be taken from whatever part of the controls is the closest to making contact with the bodywork, gauges or fairing bracket. This will give you an idea of how much rise your bike will let you have.

Special Top Mount Considerations

The motorcycle in **Figure 1** mounts the bars on top of the clamp. If you want to mount them on top of the clamp you would need a 32mm minimum of fork tube sticking up above the top surface of the triple clamp (ideally there would be 37mm).

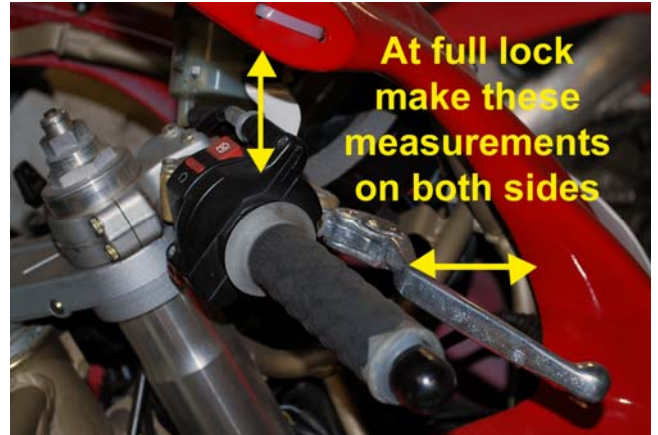

Figure 1

Determine Forward Offset

An important factor when determining if risers will work is the forward offset of the bar. **Figure 2** shows a top view of the Woodcraft riser and a second bar that represents the stock location of the bar on some models. Note that the rearward bar runs right into the fork tube, and the Woodcraft bar (in the black clamp) sits in **front** of the fork tube. This forward offset can affect clearance on some models, so you must consider this when evaluating your motorcycle. Measure the difference between your stock bars and the Woodcraft bars to determine how much offset you need to account for.

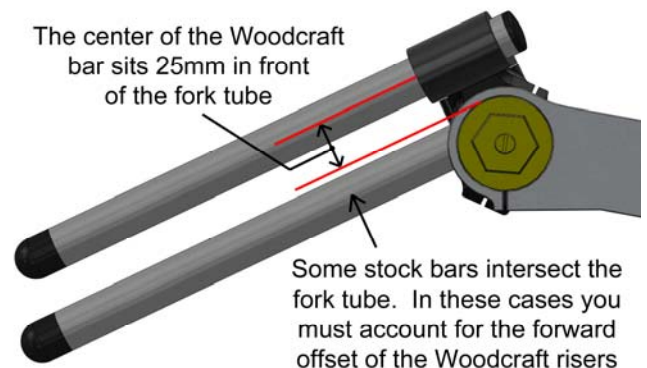

Figure 2

Triple Clamp Pinch Bolt Orientation

The orientation of the triple clamp pinch bolts is critical to the ability to use these risers. **Figure 2** shows a pinch bolt orientation that provides maximum clearance for the riser. **Figure 3** shows the worst position for the pinch bolt. There are only a few models that have this issue, but when it is present the risers cannot be used due to interference. The riser itself leaves 10mm of clearance for the triple clamp, which works on about 90% of the bikes we have encountered (shown in **Figure 4**).

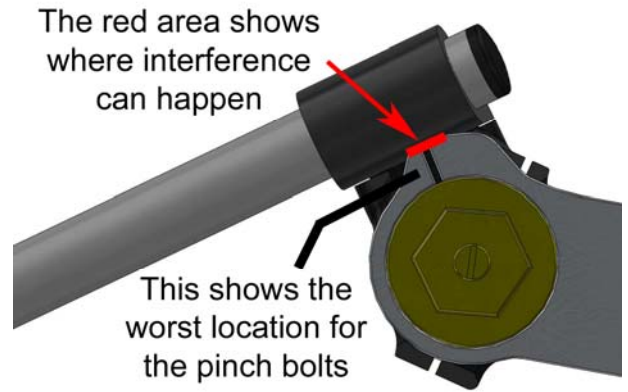

Figure 3

Brake Lines & Cables

This is one area that must be carefully attended to on each model during installation and it is very important to check cable clearance by moving the bars lock to lock several times and accounting for how the cable can move up and down. Often, it is needed to restrict the amount of motion of the cables can go through in order to avoid having them catch on things like the ignition assembly.

To determine brake line modifications you need to put the bike on a front stand and fully extend the forks to top out and be sure that there is not any tension on the lines. Most bikes start to run into issues after 1.5 - 2 inches of rise, but every model is different and must be considered individually.

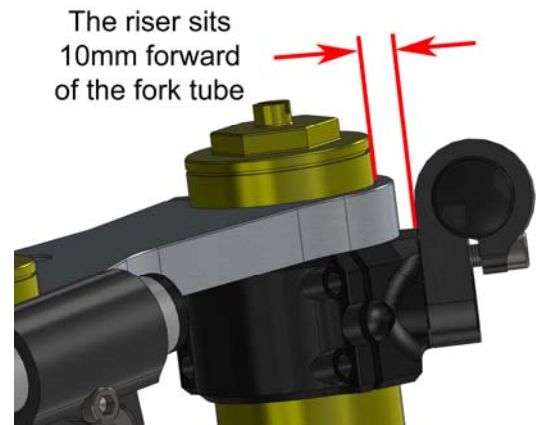

Figure 4

Determine Rise

The final step is to determine how much rise your stock handlebars have. The rise on the Woodcraft clamps is measured from the bottom edge of the triple clamp to the top of the bar clamp (see **Figure 5**). Some stock bars already have a rise with the stock clip-ons, so if you want a rise OVER the stock amount you need to get an estimate of your stock rise first and add up the stock rise and your desired additional rise. We have information on several models already....just give us a call.

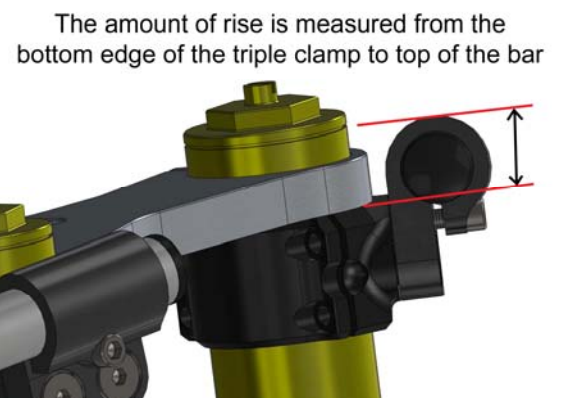

Figure 5

WOODCRAFT
Technologies, Inc.

105 Baldwinville Rd
Winchendon, MA 01475
978-297-2977
www.woodcraft-cfm.com